

The ability to install the sampler directly in the process line ensures optimal retrieval of a representative, contamination free sample. The DPT type of sampler in continuous needle purge configuration allows the product to flow directly into the sampler via an in line sample valve and to purge the needle assembly continuously before and after sampling.

1 OPERATION/FUNCTION

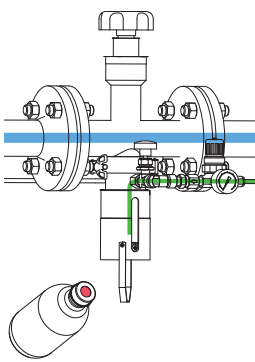

0 - off

Provide a new septum on your sample bottle. Insert the sample bottle, with cap and septum into the sleeve until the septum is pierced by the needles. Put the bottle retaining clip in place. A flow of inert gas purges needle assembly and sample bottle continuously.

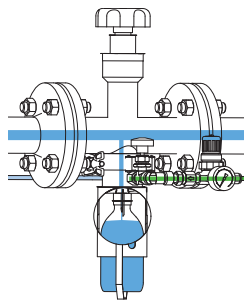

1 - sample

Turn the knob in the "sample" position allowing the product to flow into the sample bottle. When the required amount has been taken, turn the knob to the "off" position.

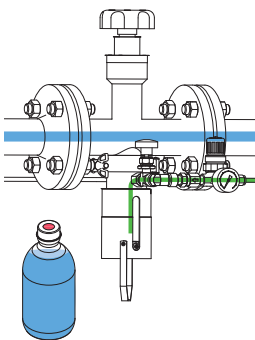

2 - off

A flow of inert gas purges needle assembly and sample bottle continuously. Remove the bottle retaining clip and pull the bottle out from the sleeve. The septum reseals automatically.

2 TYPICAL P & ID

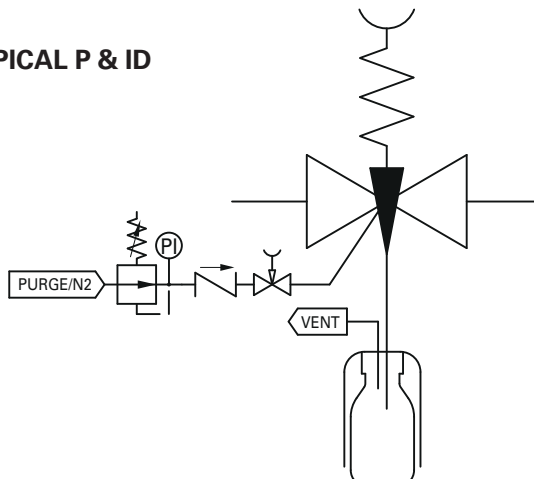

3 FEATURES/ADVANTAGES/PROPERTIES

- Sampling directly under process conditions
- Low pressure application
- Representative sampling
- Zero dead volume
- Closed sampling
- Continuous purging of needle assembly and sample bottle

4 BASIC SPECIFICATIONS

Material	SS316, SS316L.	
Sleeve type	60cc sleeve with bottle retaining clip.	
Needle assembly	Single piece VTO needle assembly with vent to outlet connection 1/4" FNPT. Process/vent needle ID: 1.35 mm.	
Valve	In line valve. PTFE seats Viton A O-ring. Pressure range 16 bar @ 20°C. Temperature range -40/+140°C (-40/+392°F).	
Operation	Manual.	
Connections	Process: 1-150 lbs. RF ANSI B16.5 flanges. Vent/purge: 1/4" FNPT.	
Please note:	the above is a basic specification only. DOPAK® Samplers can be offered with a wide variety of options as mentioned below.	

5 OPTIONS

- Lockable handle
- Enclosure
- Steam sterilising cap
- Welded connection
- Spring return handle
- Wafer style valve
- Exotic materials
- Larger/smaller sample size
- Spindle extension
- Bellow seals
- PFA lined valve
- Steam jacket

For more information please refer to our sheets:

Options for DOPAK® process samplers, sampling into a bottle.

Components for DOPAK® process samplers.

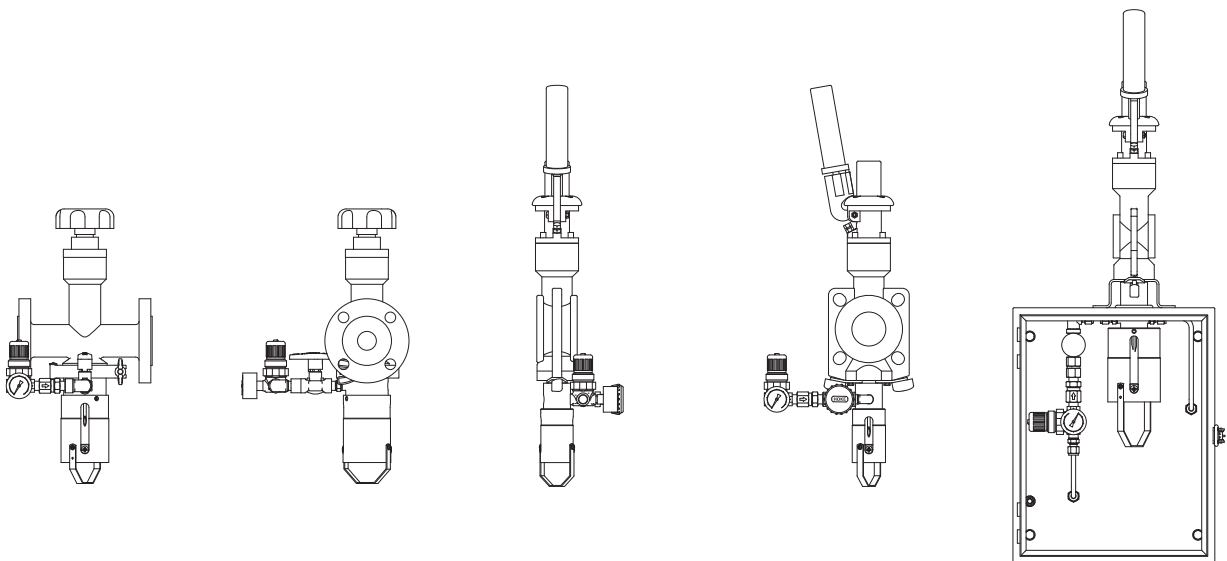

Dopak PFT Corp.

Houston, Texas 77041, USA

Phone 713-460-8311

Fax 713-460-8578

E-mail info-dopak@cranecpe.com

Dovianus BV

Bergschenhoek, The Netherlands

Phone +31 10 524 20 00

Fax +31 10 524 20 29

E-mail info-dovianus@cranecpe.com

Your local distributor

